

## Installation Instructions and Wiring Diagrams for All Models and Ranges

# SINPAC® Switches

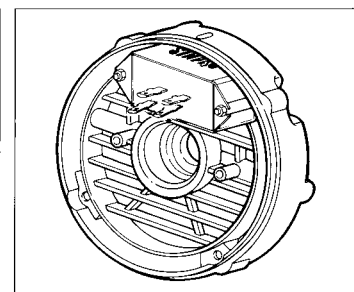
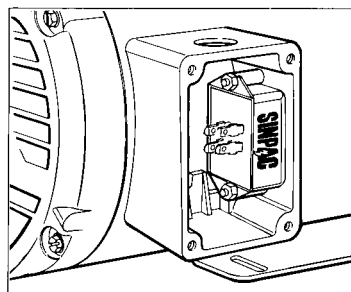
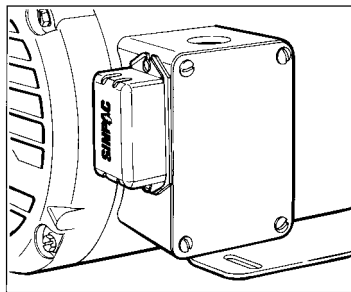
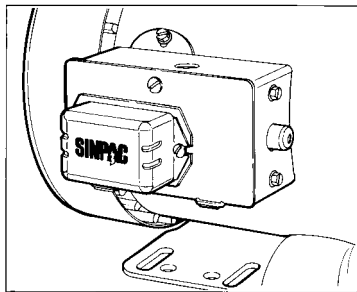

### Contents

Model and Ranges .....	1-2
Installation Instructions for SINPAC Switches .....	2-3
Wiring Diagrams for SINPAC Switches .....	4-5

Procedure for Checking SINPAC Switches .....	5
Troubleshooting Guide .....	6-7
Distributors of SINPAC Switches .....	7

# Models and Ranges

Series	Typical Max. Motor hp	Typical Full Load Motor Nameplate Current Rating (amps)			Switch Rating & Permissible Maximum Start Circuit Current (amps)	Start Circuit Voltage	Catalog Number	Part Number	Cut Out Voltage Typical	Cut Out Voltage Typical	Pkg. Style
		115 Volts	115/230 Volts	230 Volts							
PV Series Split Phase Motors Only	1/3	8	8/4		16	115	PV-16-10	4-7-11016-11-UF1	-	10	11
	1/3	8	8/4		16	115		4-7-11016-20-UF1	-	10	20
	1/3	8	8/4		16	115	PV-16-30	4-7-11016-11-UO1	-	30	11
	1/3	8	8/4		16	115		4-7-11016-20-UO1	-	30	20
	1/2			8	16	230	2PV-16-60	4-7-12016-11-NH1	-	60	11
	1/2	12	12/6		16	115	PV-25-10	4-7-11025-11-UF1	-	10	11
	1/2	12	12/6		16	115		4-7-11025-20-UF1	-	10	20
	1/2	12	12/6		16	115	PV-25-30	4-7-11025-11-UO1	-	30	11
	1/2	12	12/6		16	115		4-7-11025-20-UO1	-	30	20
	3/4	20	20/10		40	115	PV-40-30	4-7-11040-11-UO1	-	30	11
CV Series Capacitor Start Motors Only	3/4	20	20/10		40	115		4-7-11040-20-UO1	-	30	20
	1/2	8	8/4		16	115	CV-16-130	4-7-21016-11-UA1	130		30
	1/2	8	8/4		16	115		4-7-21016-20-UA1	130		30
	1/2	8	8/4		16	115	CV-16-147	4-7-21016-11-UB1	147		37
	1/2	8	8/4		16	115		4-7-21016-20-UB1	147		37
	1/2	8	8/4		16	115	CV-16-165	4-7-21016-11-UO2	165		37
	1/2	8	8/4		16	115		4-7-21016-20-UO1	165		37
	1	6	12/6		25	115	CV-25-130	4-7-21025-11-UA1	130		30
	1	6	12/6		25	115		4-7-21025-20-UA1	130		30
	1	6	12/6		25	115	CV-25-147	4-7-21025-11-UB1	147		37
	1	6	12/6		25	115		4-7-21025-20-UB1	147		37
	1	6	12/6		25	115	CV-25-165	4-7-21025-11-UO2	165		37
	1	6	12/6		25	115		4-7-21025-20-UO1	165		37
	2	20	20/10		40	115	CV-40-130	4-7-21040-11-UA1	130		30
	2	20	20/10		40	115		4-7-21040-20-UA1	130		30
	2	20	20/10		40	115	CV-40-147	4-7-21040-11-UB1	147		37
	2	20	20/10		40	115		4-7-21040-20-UB1	147		37
	2	20	20/10		40	115	CV-40-165	4-7-21040-11-UO2	165		37
	2	20	20/10		40	115		4-7-21040-20-UO1	165		37
	3	25	25/12.5		50	115	CV-50-130	4-7-21050-12-UA1	130		30
3	25	25/12.5		50	115		4-7-21050-20-UA1	130		30	

Series	Typical Max. Motor hp	Typical Full Load Motor Nameplate Current Rating (amps)			Switch Rating & Permissible Maximum Start Circuit Current (amps)	Start Circuit Voltage	Catalog Number	Part Number	Cut Out Voltage Typical	Cut Out Voltage Typical	Pkg. Style
		115 Volts	115/230 Volts	230 Volts							
CV Series Capacitor Start Motors Only	3	25	25/12.5		50	115	CV-50-147	4-7-21050-12-UB1	147		37
	3	25	25/12.5		50	115		4-7-21050-20-UB1	147		37
	3	25	25/12.5		50	115	CV-50-165	4-7-21050-12-UO1	165		37
	3	25	25/12.5		50	115		4-7-21050-20-UO1	165		37
	1/2	8	8/4		16	115	VR-16-130	4-7-71016-12-UA1	130	30	12
VR Series Capacitor Start/ Capacitor Run Motors Only	1/2	8	8/4		16	115		4-7-71016-19-UA1	130	30	19
	1/2	8	8/4		16	115	VR-16-147	4-7-71016-12-UB1	147	37	12
	1/2	8	8/4		16	115		4-7-71016-19-UB1	147	37	19
	1/2	8	8/4		16	115	VR-16-165	4-7-71016-12-UO1	165	37	12
	1/2	8	8/4		16	115		4-7-71016-19-UO1	165	37	19
	2	20	20/10		40	115	VR-40-130	4-7-71040-12-UA1	130	30	12
	2	20	20/10		40	115		4-7-71040-19-UA1	130	30	19
	2	20	20/10		40	115	VR-40-147	4-7-71040-12-UB1	147	37	12
	2	20	20/10		40	115		4-7-71040-19-UB1	147	37	19
	2	20	20/10		40	115	VR-40-165	4-7-71040-12-UO1	165	37	12
	2	20	20/10		40	115		4-7-71040-19-UO1	165	37	19
	3	25	25/12.5		50	115	VR-50-130	4-7-71050-12-UA1	130	30	12
	3	25	25/12.5		50	115		4-7-71050-19-UA1	130	30	19
	3	25	25/12.5		50	115	VR-50-147	4-7-71050-12-UB1	147	37	12
	3	25	25/12.5		50	115		4-7-71050-19-UB1	147	37	19
3	25	25/12.5		50	115	VR-50-165	4-7-71050-12-UO1	165	37	12	
3	25	25/12.5		50	115		4-7-71050-19-UO1	165	37	19	
CVR Series Cap Start & Capacitor Start/Cap. Run Motors Only	3-5	50	50/25		80	115	CVR-80-130	4-7-41080-15-NA1	130	30	15
	3-5	50	50/25		80	115	CVR-80-147	4-7-41080-15-NB1	147	37	15
	3-5	50	50/25		80	115	CVR-80-165	4-7-41080-15-NO1	165	37	15
2CV Series Capacitor Start Motors Only	3			17.5	35	230	2CV-35-260	4-7-22035-15-UC1	260	70	15
	3			17.5	35	230	2CV-35-310	4-7-22035-15-UO1	310	70	15
	5			25	50	230	2CV-50-260	4-7-22050-15-UC1	260	70	15
	5			25	50	230	2CV-50-310	4-7-22050-15-UO1	310	70	15

## Models and Ranges (continued)

Series	Typical Max. Motor hp	Typical Full Load Motor Nameplate Current Rating (amps)			Switch Rating & Permissible Maximum Start Circuit Current (amps)	Start Circuit Voltage	Catalog Number	Part Number	Cut Out Voltage Typical	Cut In Voltage Typical	Pkg. Style
		115 Volts	230 Volts	230 Volts							
2VR Series Capacitor Start/Cap. Run Motors Only	3		17.5	35	230	2VR-35-260	4-7-72035-15-UC1	260	70	15	
	3		17.5	35	230	2VR-35-310	4-7-72035-15-UO1	310	70	15	
	5		25	50	230	2VR-50-260	4-7-72050-15-UC1	260	70	15	
	5		25	50	230	2VR-50-310	4-7-72050-15-UO1	310	70	15	
2CVR Series Capacitor Start and Capacitor Start/Cap. Run Motors Only	7.5		35	70	230	2CVR-70-260	4-7-42070-17-UC1	260	70	17	
	7.5		35	70	230	2CVR-70-310	4-7-42070-17UO1	310	70	17	
IR Series Instant Reverse Capacitor Start Motors Only	1/2	12	12/6	25	115	IR-25-130	4-7-51025-15-UA1	130	30	15	
	1/2	12	12/6	25	115	IR-25-147	4-7-51025-15-UB1	147	33	15	
	1/2	12	12/6	25	115	IR-25-165	4-7-51025-15-UO1	165	37	15	
	2	20	20/10	40	115	IR-40-130	4-7-51040-15-UA1	130	30	15	
	2	20	20/10	40	115	IR-40-147	4-7-51040-15-UB1	147	33	15	
2	20	20/10	40	115	IR-40-165	4-7-51040-15-UO1	165	37	15		

## Installation Instructions for SINPAC® Switches

### UL Recognition

Most SINPAC Switches are recognized under the component program of Underwriters Laboratories E-71115. In addition, all switches have an internal surge protection which meets UL-244A Specification and CSR Certification LR-6254, and are tested to the requirement of IEEE C62.41-1991, Category A3.

### Construction

SINPAC Switches are potted and completely sealed making them impervious to dust, dirt and moisture. It can be immersed in electric grade oil as used in submersible pumps. The unique speed sensing circuit provides a universal design which allows a few switches to work in most standard single-phase motor applications regardless of nature.

### Operation

The Stearns SINPAC Switch samples the voltage across the motor start winding (terminals 1 and 4) then it is fed into a

comparator. The SINPAC Switch interrupts the start capacitor current (between terminals 2 and 3) after the motor has accelerated to a speed in which the cut out voltage has been reached, generally 75% to 80% of synchronous motor speed. A triac or inverse parallel SCRs provides the function referred to as cut out. Once the start circuit is cut out the main winding accelerates the motor rotor up to its running speed. When an overload drops the motor speed to approximately 50% of synchronous speed the switch automatically reconnects the motor start circuit. The SINPAC Switch constantly monitors the start or auxiliary winding for cut in voltage and will reconnect the start circuit once cut in voltage is reached.

### Selection Procedure

**CAUTION:** SINPAC Switches are line voltage compensated. Changes in the line voltage within  $\pm 10\%$  of nominal 115 or 230 Vac will not affect system operation. Operation of the motor at line voltages less than -10% of nominal can result in reduced motor running speeds and failure of the SINPAC Switch to disconnect the start circuit.

1. Be sure switch series matches motor type.
2. Be sure switch voltage rating matches the motor start circuit voltage.
3. Selection should be based on actual measurement of start circuit current.
4. SINPAC Switch current rating must **meet or exceed** the motor start circuit current requirement. Always select a SINPAC Switch with the next higher current rating for:
  - a) High cycling applications: Stop and start rates greater than 4 times/minute.
  - b) Long acceleration times: Greater than 5 seconds.

c) High ambients: Ambients greater than 55°C.

**Note:** Higher rated current switches can be used in place of lower rated switches within the same series.

5. The motor must generate a voltage across the start or auxiliary winding that is 20% greater than the SINPAC Switch cut out/cut in voltage rating.

### Capacitor Start and Capacitor Start/ Capacitor Run Motors

To determine the most appropriate SINPAC Switch cut out voltage rating for the particular motor application, the voltage across the motor start or auxiliary winding must be measured. This may be accomplished in the following manner:

1. Prepare the motor wiring for connection of the SINPAC Switch as shown in the *Wiring Diagrams for SINPAC Switches* section of this publication. Secure the motor to a firm mounting surface.
2. Connect the lead wire that is to be connected to SINPAC Switch terminal #2 securely to the lead wire that is to be connected to SINPAC Switch terminal #3.
3. Connect an AC voltmeter across the lead wires that are to be connected to SINPAC Switch terminals #1 and #4.
4. Apply power to the motor. Observe and record the voltage across the motor start or auxiliary winding, as indicated by the AC voltmeter, with the motor operating near synchronous speed.

**CAUTION:** Measurement of the start or auxiliary winding voltage must be done quickly to prevent damage to the start capacitor, motor winding or SINPAC Switch!

5. Multiply the measured voltage by 0.8 (80%). Select a SINPAC Switch having a cut out voltage rating equal to or less than this number.

Measured Voltage	Voltage Across SINPAC Switch Terminals 1 & 2	Cut Out Voltage Rating
>226V	115V	180V
>200-225V	115V	165V
176-200V	115V	147V
150-175V	115V	130V
<150V	115V	*
>492V	230V	410V
370-492V	230V	310V
300-369V	230V	260V
<300V	230V	*

\*Consult factory

## Installation Instructions for SINPAC® Switches (continued)

### Split Phase Motors

To determine the most appropriate SINPAC Switch cut in voltage rating for the particular motor application, the voltage across the motor start winding must be measured. This may be accomplished in the following manner:

1. Prepare the motor wiring for connection of the SINPAC Switch as shown in the *Wiring Diagrams for SINPAC Switches* section of this publication. Secure the motor to a firm mounting surface.
2. Insulate the lead wire that is to be connected to SINPAC Switch terminal #2.
3. Connect an AC voltmeter across the lead wires that are to be connected to SINPAC Switch terminals #1 and #3.
4. Apply power to the motor. Carefully rotate the motor shaft to initiate rotation. Observe and record the voltage across the motor start winding, as indicated by the AC voltmeter, with the motor operating near synchronous speed.
5. Multiply the measured voltage by 0.8 (80%). Select a SINPAC Switch having cut in voltage rating closest to this number.

### Split Phase Motors

Measured Voltage	Voltage Across SINPAC Switch Terminals 1 & 2	Cut In Voltage Rating
>40V	115V	30V
15-40V	115V	10V
<15V	115V	*
>70V	230V	60V
<70V	230V	*

\*Consult factory

### Important

Please read these instructions carefully before installing, operating, or servicing your SINPAC Switch. Failure to comply with these instructions could cause injury to personnel and/or damage to property if the switch is installed or operated incorrectly. For definition of limited warranty/liability, contact Rexnord Corporation, Stearns Division, 5150 S. International Dr., Cudahy, Wisconsin 53110, (414) 272-1100.

**Caution: Application of 230 Vac to the line input terminals (1 and 2) of a 115 Vac rated SINPAC Switch will result in immediate switch failure. The switch may rupture and emit smoke.**

### Initial Inspection and Handling

Upon receipt, check for package damage. Note any signs of damage on appropriate shipper forms. Upon opening package, if concealed damage is found, immediately file a claim with carrier.

Check the label to verify that data conforms to specifications of ordered switch and the connection diagram agrees with labeling.

### Caution

1. Installation and servicing must be made in compliance with all local safety codes including Occupational safety and Health Act (OSHA). All wiring and electrical connections must comply with the National Electric Code (NEC) and local electric codes in effect.
2. To prevent an electrical hazard, disconnect power source before working on the motor. If power disconnect point is out of sight, lock disconnect in the *off* position and tag to prevent accidental application of power.
3. Make certain power source conforms to the requirements specified on the SINPAC Switch nameplate.
4. Installation and servicing should be performed only by qualified personnel familiar with the operation of the SINPAC Switch.
5. Determine what type of start switch the motor presently has:
  - a) Externally mounted electronic switch – go to Step 6.
  - b) Internally mounted electronic switch – go to Step 6.
  - c) Externally or internally mounted mechanical switch – it is not necessary to remove the existing centrifugal switch actuating mechanism, but if feasible, it should be removed as it is no longer needed, and can cause future mechanical problems in the motor should the mechanism fail. Follow the manufacturers recommendation when removing the shaft end bearing, if necessary, to take off the centrifugal actuator.
6. Remove the existing electronic switch. Determine the existing wiring diagram. Mark the existing wires and determine which wires can be reused for installation of the SINPAC Switch. Select a location in the motor conduit box or endbell for mounting the SINPAC Switch.

If a metal enclosure version of SINPAC Switch is being used, the switch with SINPAC Switch gasket may be mounted on an external mounting surface such as the exterior of the conduit box. Plastic enclosure versions of the SINPAC Switch should be mounted internally, within the conduit box, or externally, under a capacitor housing.









**IMPORTANT: SINPAC Switch in a metal enclosure must have the metal enclosure grounded.**



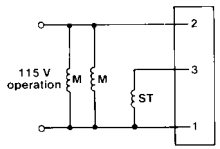
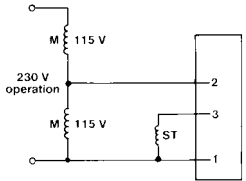

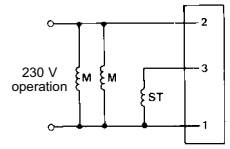

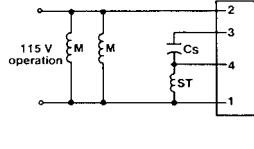
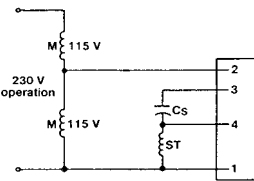
**The temperature at the mounting location should not exceed 65°C (149°F). (2CVR temperature should not exceed 55°C.)**

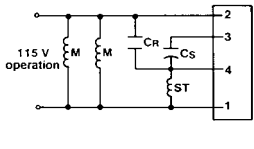
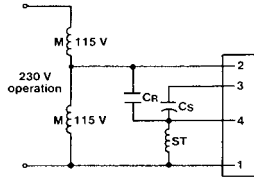
**TEFC/TENV motors require external mounting of SINPAC Switch.**

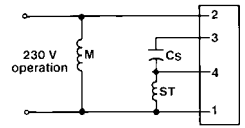
7. Refer to motor manufacturer's wiring diagram to aid in identifying terminal locations for the start winding switch, start winding, start and run capacitors (if needed) and AC line.
8. Connect the SINPAC circuit per the connection diagram (on Pages 9-11) using insulated terminals. If the connections are made incorrectly, the result will be no starting torque and possible damage to the circuit and/or motor.  
**CAUTION:** Be sure that appropriate insulation is used between the terminals of the switch and the body of the motor or conduit box.  
**If mounted external to motor, always use gasket supplied with kit.**
9. DO NOT USE a Variac to gradually increase the voltage to the motor starting circuit when SINPAC Switch is installed.
10. Reassemble the motor with SINPAC Switch installed, so as to not damage lead wires.
11. If the motor fails to start or the start winding does not cut out properly, see *Troubleshooting Guide* (Page 13-14).
12. Hipot test procedures:  
**Motors 250 Volts or Less and 1/2 Horsepower or Less**  
The motor, equipped with SINPAC Switch, shall be tested for dielectric withstand (hipot), by the application of a 1200 volt sinusoidal potential, in the range of 40-70 Hz, for 1 second. During the test, each lead of the primary motor wiring, accessible at the connection board or conduit box, are to be connected together and to one terminal of the test equipment, and the second test equipment terminal is to be connected to the accessible dead metal.  
**Motors 250 Volts or Less and More Than 1/2 Horsepower**  
The motor, equipped with SINPAC Switch, shall be tested for dielectric withstand (hipot), by the application of an 1800 volt sinusoidal potential, in the range of 40-70 Hz, for 1 second. During the test, each lead of the primary motor wiring, accessible at the connection board or conduit box, are to be connected together and to one terminal of the test equipment, and the second test equipment terminal is to be connected to the accessible dead metal.
13. **CAUTION:** The terminals of the SINPAC Switch should not be used as the junction for this field wiring.

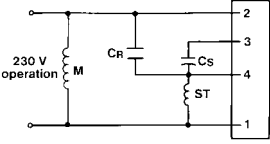
# Wiring Diagrams for SINPAC® Switches

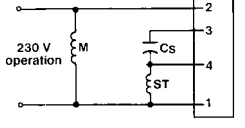
Catalog Number	SINPAC Switch Rating	115 Volt 50/60 Hz Motor Operation	230 Volt 50/60 Hz Motor Operation
<b>PV-16</b> <b>PV-25</b> <b>PV-40</b> <i>Connect to Split Phase Motors Only</i>	115 Volts  		
<b>2PV-16</b> <i>Connect to Split Phase Motors Only</i>	230 Volts  	<i>Not Applicable</i>	
<b>CV-16</b> <b>CV-25</b> <b>CV-40</b> <b>CV-50</b> <b>CVR-40</b> <b>CVR-50</b> <i>Connect to Capacitor Start Motors Only</i>	115 Volts  		
<b>VR-16</b> <b>VR-40</b> <b>VR-50</b> <b>CVR-40</b> <b>CVR-50</b> <b>CVR-80</b> <i>Connect to Cap. Start/ Capacitor Run Motors</i>	115 Volts  		

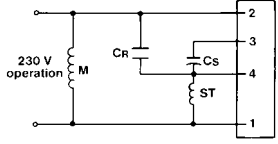
Catalog Number	SINPAC Switch Rating	115 Volt 50/60 Hz Motor Operation	230 Volt 50/60 Hz Motor Operation
<b>2CV-35</b> <b>2CV-50</b> <i>Connect to Capacitor Start Motors Only</i>	230 Volts 	<i>Not Applicable</i>	
<b>2VR-35</b> <b>2VR-50</b> <i>Connect to Capacitor Start/ Capacitor Run Motors</i>	230 Volts 	<i>Not Applicable</i>	
<b>2CVR-70</b> <i>Connect to Capacitor Start Motors</i>	230 Volts 	<i>Not Applicable</i>	
<b>2CVR-70</b> <i>Connect to Capacitor Start/ Capacitor Run Motors</i>	230 Volts 	<i>Not Applicable</i>	

**CS** – Start Capacitor,  
**M** – Motor Main Winding,

**CR** – run Capacitor,  
**ST** – Motor Start Winding

## Wiring Diagrams for SINPAC® Switches (continued)

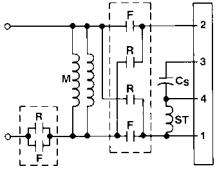
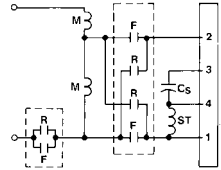
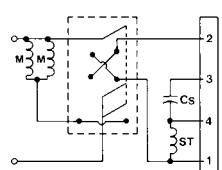
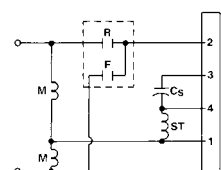
Catalog Number	SINPAC Switch Rating	115 Volt 50/60 Hz Motor Operation	230 Volt 50/60 Hz Motor Operation
<b>IR-25</b> <b>IR-40</b>  Connect to Instant Reverse Capacitor Start Motors Only	115 Volts  	<b>115 Volt Operation Dual Voltage Motor Using Two Full Voltage 2 or 3 Pole Single-Phase Reversing Contactors with Mechanical Interlock (Electrical Interlock Optional)</b>   <p>Reversing contacts are not part of SINPAC Switch.</p>	<b>230 Volt Operation Dual Voltage Motor Using Two Full Voltage 2 or 3 Pole Single-Phase Reversing Contactors with Mechanical Interlock (Electrical Interlock Optional)</b>   <p>Reversing contacts are not part of SINPAC Switch.</p>
		 <p>Drum switch is not part of SINPAC Switch.</p>	 <p>Reversing contacts are not part of SINPAC Switch.</p>

**CS** – Start Capacitor,

**CR** – run Capacitor,

**M** – Motor Main Winding,

**ST** – Motor Start Winding

## Procedure for Checking SINPAC® Switches

1. Disconnect the SINPAC Switch from the motor and measure the resistance between terminals 2 and 3. If the resistance is less than 500K, the SINPAC Switch has been shorted or damaged, and must be replaced. If the resistance is infinite, the switch may not be damaged.

**CAUTION:** Do not use megger to test motor circuit with SINPAC Switch. Proceed to Step 3 if you have a PV switch.

2. If resistance across SINPAC terminal 2 and 3 is greater than 500K and you have a capacitor start, instant reverse, or capacitor start/capacitor run SINPAC Switch, use Diagram 1.

115 V SINPAC Switch – 115 V incandescent light (L) (at least 25 watts) and 115 Vac power source.

230 V SINPAC Switch – 230 V incandescent light (L) (at least 25 watts) in series and 230 Vac power source.

**Diagram 1**

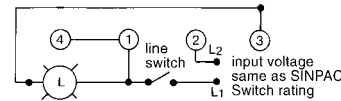

- Connect one line of AC power to terminal 1 through a line switch.
- Connect incandescent light (L) between terminals 1 and 3 of SINPAC Switch.
- Jumper terminals 1 and 4 of SINPAC Switch.
- Connect other line of AC power to terminal 2 of SINPAC Switch.

**Note 1:** Apply rated AC voltage to the SINPAC Switch.

**Note 2:** The incandescent light (L) will illuminate if the SINPAC Switch is operable.

**Note 3:** If the incandescent light (L) fails to illuminate, the SINPAC Switch has been damaged and must be replaced.

**Note 4:** Turn off voltage and disconnect the SINPAC Switch.

- If resistance across SINPAC terminal 2 and 3 is greater than 500K and you have a split phase SINPAC Switch, use Diagram 2.

**Diagram 2**

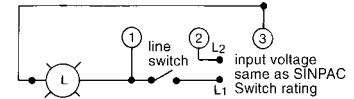

- Connect one line of AC power to terminal 1 through a line switch.
- Connect a (25 watt) incandescent light (L) between terminals 1 and 3 of SINPAC Switch.
- Connect other line of AC power to terminal 2 of SINPAC Switch.

**Note 1:** Apply rated AC voltage to the SINPAC Switch.

**Note 2:** If the incandescent light (L) begins to blink after 1/2 second, the SINPAC Switch is operable.

**Note 3:** If the incandescent light (L) fails to illuminate or stays illuminated, the SINPAC Switch has been damaged and must be replaced. Both tests must be performed and passed to indicate a minimally good switch.

**Note 4:** Turn off power and disconnect the SINPAC Switch.

## Troubleshooting Guide

Symptom	Possible Cause	Procedure for Checking	Corrective Action
Motor fails to start.	Incorrect connection of SINPAC Switch.	De-energize. Check the wiring and connection diagram.	Reconnect properly.
	Start capacitor open or shorted.	De-energize motor, discharge, and check capacitor.	Replace capacitor.
	Thermal overload opened.	Check thermal overload. Check motor and SINPAC Switch wiring.	Wait until cool down. Check/replace thermal overload. Correct motor and SINPAC Switch wiring.
	Motor not free to rotate.	Check for jam or obstruction.	Remove obstruction.
	AC line voltage too low.	Measure line voltage at the motor terminals.	Increase voltage.
	No line voltage.	De-energize, check AC line fuses. Check wiring and connection diagram.	Replace fuses as required and apply AC line voltage.
	Start winding open.	De-energize and disconnect. Measure the resistance of the start winding.	Check the start winding. Motor may have to be rewound. Infinite resistance would show an open winding or loose connection.
	Motor hipot tested with switch installed without motor and SINPAC Switch leads tied together.	See <i>Procedure</i> to check SINPAC Switch (Page 12)	Replace switch and hipot motor, with installed SINPAC Switch, by tying all motor and SINPAC Switch leads together.
	SINPAC Switch damaged (open circuit).	See <i>Procedure</i> to check SINPAC Switch (Page 12)	Replace SINPAC Switch after checking all of the above possible causes
SINPAC Switch, if it has a metal enclosure, is not grounded.	Check continuity between SINPAC Switch metal case and ground.	Ground metal case.	
Current in the start winding is above rating of SINPAC Switch.	Remove switch and check the current of the start winding. See <i>Procedure</i> to check SINPAC Switch (Page 12).	Replace SINPAC Switch, if damaged.	

Symptom	Possible Cause	Procedure for Checking	Corrective Action
Motor fails to start.	Wrong series SINPAC Switch installed — 115 V SINPAC Switch connected to 230 V start winding.	Consult selection chart — Measure voltage across wires connected to terminals 1 and 2.	Change switch — Check SINPAC Switch for damage and replace with correct switch.
	Start capacitor shorted.	De-energize motor, discharge and check the capacitor.	Replace capacitor.
	Start winding induced voltage is too low when motor reaches desired cut out speed. The voltage is due to the low winding-ratio of certain old style motors, foreign motors, converted motors, and special motor designs.	Perform SINPAC Switch Selection <i>Procedure</i> as described on Page 12.	Select proper SINPAC Switch.
	AC line voltage too low.	Measure the AC line voltage across the motor terminals.	Increase the AC line voltage.
	Start winding damaged.	De-energize and check the start winding.	Rewind motor.
	Mismatch of motor and load. Motor cannot reach cut out speed.	Check the load and motor characteristics.	Reduce load. Replace the motor with an appropriately larger sized motor.
	Incorrect connection of SINPAC Switch for capacitor start motors.	De-energize and check the connection diagram. Be sure that terminal 4 of switch is connected to the junction of the start capacitor and start winding (Pages 9-11).	Correct wiring.
	Damaged SINPAC Switch.	See <i>Procedure</i> to check SINPAC Switch (Page 12).	Replace SINPAC Switch after checking all of above possible causes.
	SINPAC Switch exposed to excessive temperature.	Check the operating ambient temperature of SINPAC Switch. It should be less than 80°C (185°F).	Change mounting location of switch. SINPAC Switches can be remotely mounted.

## Troubleshooting Guide (continued)

Symptom	Possible Cause	Procedure for Checking	Corrective Action
Upon overload, the start winding is not reenergized (no cut in)	Wrong switch installed. (PV Series switch on capacitor start motor.)	Consult selection chart.	Install correct switch.
Motor worked properly for many cycles of operations (days, weeks, months, years), then failed.	Start capacitor failure on capacitor start or cap. start/cap. run motors.	De-energize motor and check capacitor and SINPAC Switch.	Replace start capacitor and SINPAC Switch as appropriate.
	Switch failure.	See <i>Procedure</i> to check SINPAC Switch. Also check start capacitor (Page 12).	Replace switch.
Premature start capacitor failures.	High cycle rate. Excessive motor temperature.	De-energize motor and check start capacitor and SINPAC Switch.	Connect a 15,000 ohm, 2 watt bleeder resistor across the start capacitor(s).  If a single start capacitor was originally installed, replace with two start capacitors of twice the capacitance value and same voltage rating as the original and connected in series.
Instant reverse motor, upon rapid reverse, will not reverse direction.	Wrong switch installed. CV or VR Series installed instead of instant reverse SINPAC Switch.	Ensure that instant reverse SINPAC Switch was installed to replace any mechanical instant reversing switch.	Install SINPAC instant reverse switch.

## Distributors of SINPAC® Switches

### **Brownell Electro, Inc.**

1-800-774-4643

### **E.I.S. Holden, Inc.**

Atlanta, GA 1-800-447-0135  
 Charlotte, NC 1-800-235-9491  
 Denver, CO 1-800-367-8333  
 Minneapolis, MN 1-800-328-4662  
 Philadelphia, PA 1-800-367-1212  
 San Francisco, CA 1-800-347-9611

### **Torq Corporation**

Bedford, OH (440) 232-4100  
 1-800-899-5533

### **Canada**

#### **Acme Electric, Ltd.**

Port Hope, Ontario  
 Canada L1A 3W3  
 (905) 885-2469

#### **C.B.S. Electrical Insulation Materials, Ltd.**

Calgary-AB Canada T2G 4C8  
 (403) 243-9409  
 Coquitlam-BC Canada V3K 6A9  
 (604) 945-3634

Edmonton-AB Canada T5H 3E8  
 (780) 423-4301

### **Puerto Rico**

#### **Prowire Inc.**

San Juan, Puerto Rico  
 (787) 648-1725

Copyright© 2000 by Rexnord Industries, Inc.

*Rexnord Industries, Inc.*  
*Stearns Division*  
*5150 S. International Dr.*  
*Cudahy, Wisconsin 53110*  
*(414) 272-1100 Fax: (414) 277-4364*