



# KLIXON® | Large Frame PDL Series (PDLM, PDLA)

## 35 to 150 Amp Precision Thermal Circuit Breaker

### FEATURES

- 30VDC, 35 to 150 Amps
- Sealed assemblies, available in manual and automatic reset options
- Ignition protected & CCC certified
- PDLM meets CID A-A-55571/04 specifications
- PDLA meets CID A-A-55571/07 specifications

### DESCRIPTION

The KLIXON® PDL series thermal breakers are designed to meet the harshest environmental requirements. The PDL series breakers are weatherproof for protection against moisture, dust, grease, fuel vapors, and other harsh environments. The PDL series of breakers are designed to interrupt short circuits or overloads and combine trip-free protection with fast response time. The PDL series of breakers can be used in commercial and military vehicles and equipment where more precise ultimate trip characteristics are required.

### ORDERING INFORMATION

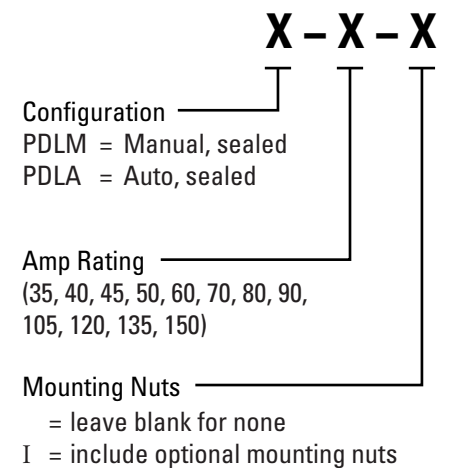

### PERFORMANCE CHARACTERISTICS

Calibration : 200% rated current, 77°F (25°C)	8 to 100 seconds
Ultimate Trip At 77°F (25°C)	Must hold 100%, Must trip 138%
Endurance	Automatic: 2,000 cycles @ 200% rated current Manual: 500 cycles @ 200% rated current
Interrupt Current Capacity	Per SAE J1625 and ABYC E-11
Vibration	10G MIL-STD-202 Method 204, Condition A
Mechanical Shock	100G MIL-STD-202 Method 213, Condition C
Dielectric Strength	MIL-STD-202 Method 301, 1500VAC min
Insulation Resistance	MIL-STD-202 Method 302, Condition B, 100 MΩ min
Weight (with mounting nuts)	PDLM : 129 grams max PDLA : 116 grams max

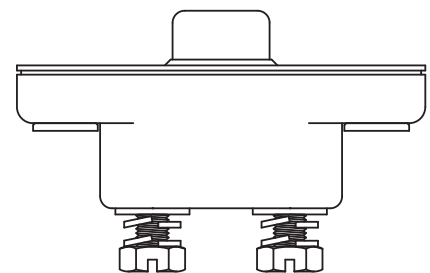

## TRIP CURVE - Approximate Time, Current Characteristics At 77°F (25°C)

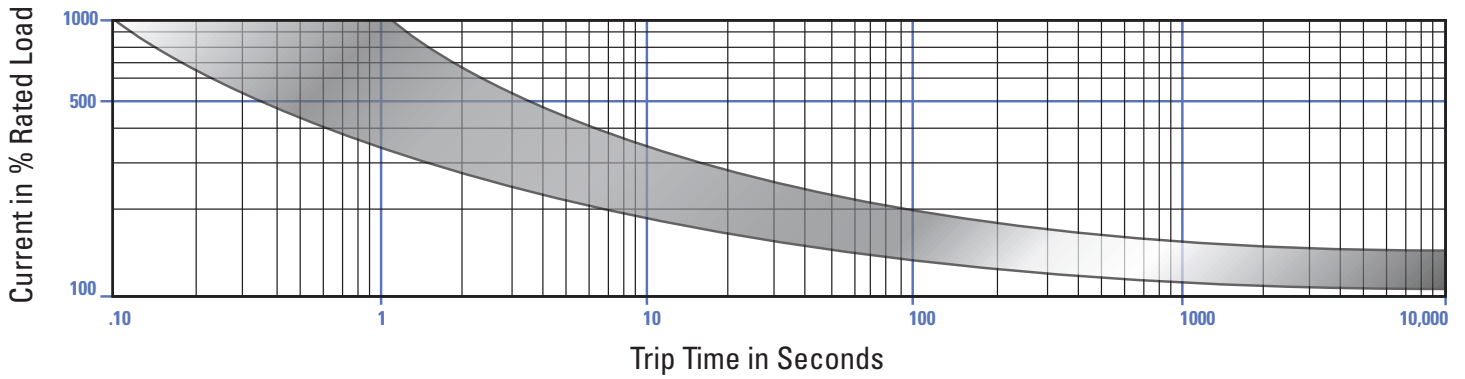

## DIMENSIONS - PDLM

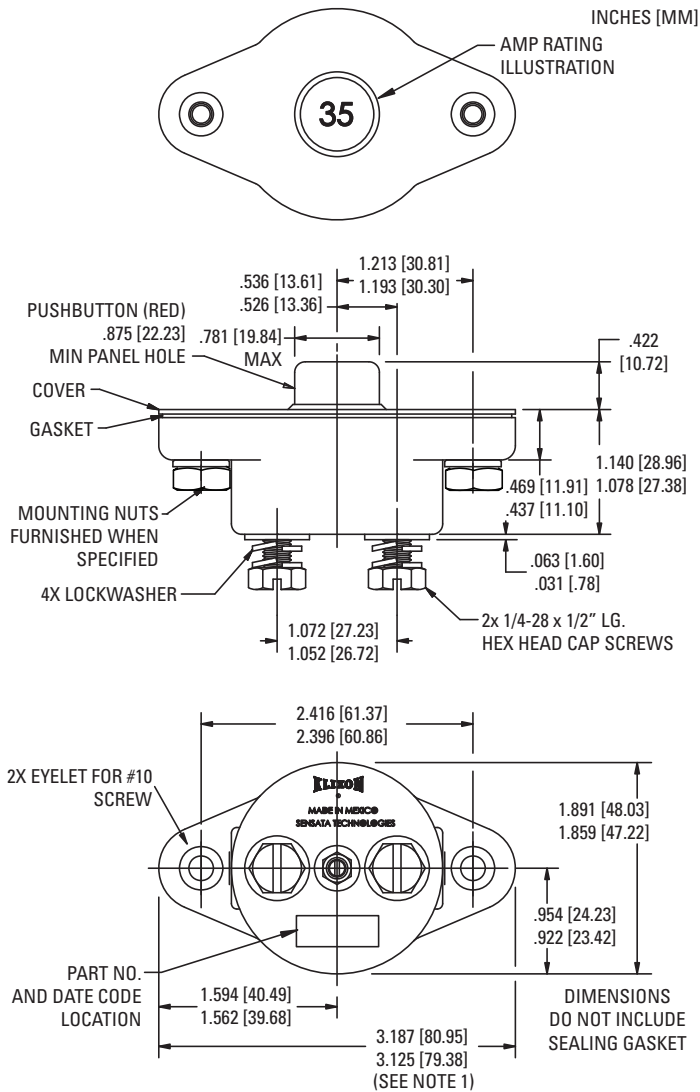

## DERATING CURVE

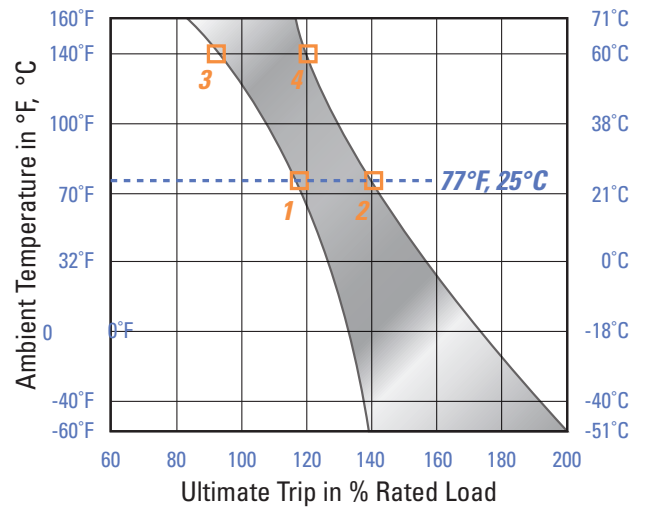

Performance characteristics are based on room temperature (77°F, 25°C). Consult Derating curve for ambient temperatures significantly higher or lower than standard room temperature.

Example: At 77°F (25°C) the device is calibrated to hold at 110% of rated current (1) and trip at 138% of rated current (2). At 140°F (60°C), the same device will hold at approximately 92% of rated current (3), and trip at approximately 120% of rated current (4).



The World Depends on Sensors and Controls

Sensata Technologies Inc.

529 Pleasant Street  
Attleboro, MA 02703, USA  
Phone: +1 508-236-3287

<http://www.sensata.com/>

Important Notice: Sensata Technologies (Sensata) reserves the right to make changes to or discontinue any product or service identified in this publication without notice. Sensata advises its customers to obtain the latest version of the relevant information to verify, before placing any orders, that the information being relied upon is current. Sensata assumes no responsibility for infringement of patents or rights of others based on Sensata applications assistance or product specifications since Sensata does not possess full access concerning the use or application of customers' products. Sensata also assumes no responsibility for customers' product designs.