

TEXAS INSTRUMENTS 4TM THERMAL PROTECTOR PRODUCT BULLETIN

- **Plug-on thermal motor protector for compressors**
- **Protects compressors for refrigerators, freezers, dehumidifiers, water coolers, vending machines, and similar refrigeration applications**
- **Compatible with PTCR starters and electro-mechanical relays**
- **Product designed and manufactured in environment of *Total Quality Control***
- **Applicable to compressors manufactured around the world**
- **Conforms with worldwide certification agency standards**

Benefits

• Cost

The 4TM's patented plug-on feature and our fully automated manufacturing module provide 4TM customers with the minimum *total installed cost*.

• Quality

TI has designed quality into the 4TM product and process to meet a higher quality standard based on Statistical Process Control techniques.

Each 4TM production lot is accompanied by a "Certified Quality Report." This document certifies, based on statistical methods, the lot's compliance with temperature, trip time and other specifications. Supplying certified devices eliminates our customer's need for incoming inspection of the 4TM.

• Performance

The basic function of the 4TM is to protect the motor in a refrigeration compressor from overheating, resulting from locked rotor or running overload conditions. The 4TM provides this protection by sensing the current and temperature of the motor.

The fundamental actuation principle incorporates a non-current carrying snap-acting disc, which is located above the heater element. (REFER TO BACK PAGE FOR REFERENCE DRAWINGS). In addition to radiant heat generated from the heater, compressor shell, and ambient, the disc senses the heat from the metal pin carrying line current through the hermetic terminals. When the disc snaps, it actuates the spring arm located above the disc, opening the contact circuit - which shuts off the compressor motor. The operating parameters of the 4TM are

not affected by contact wear because the contacts are not part of the resistance circuit and are not part of the temperature calibration mechanism.

The patented design features of the 4TM have resulted in the following performance and reliability improvements:

- **Longer off-times for better matching and compatibility with PTCR starters**
- **Better repeatability of trip time and ultimate trip**
- **Minimum temperature drift versus life cycles**
- **Excellent resistance to physical and thermal shock**

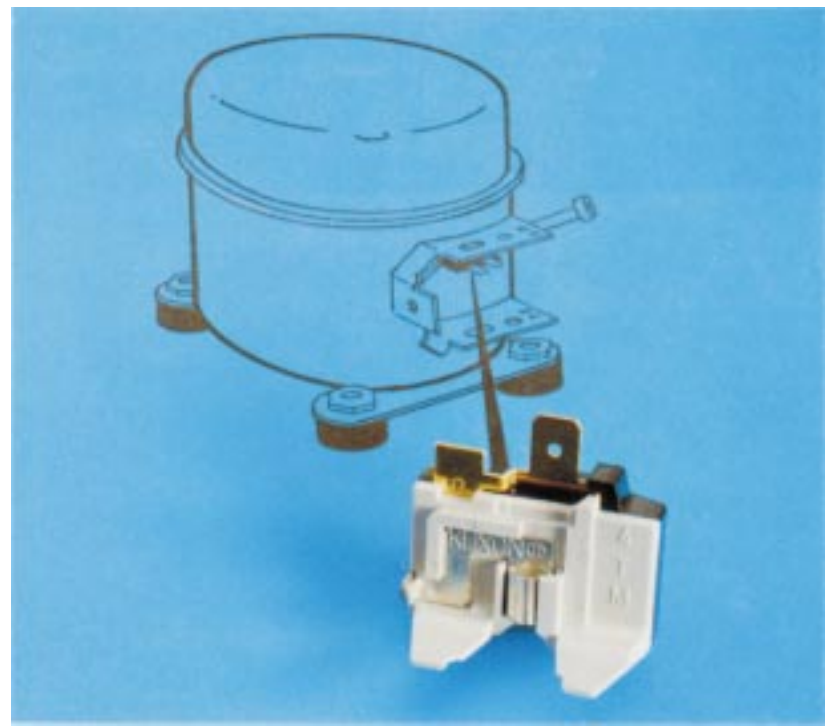

Refrigeration Compressor Motor Protector Application Procedure

Test Conditions:

The 4TM is normally applied on refrigeration compressors.* There are several standard or typical types of fault conditions, for which a thermal protector's characteristics should be appropriate:

• Pull Down

The protector must have sufficient current carrying capacity to allow the compressor to run under heavy load conditions. Typically, the heaviest load occurs under a pull down condition of a refrigerator cabinet. This is a condition where under the hottest specified ambient, a refrigerator is required to pull down from a soaked out room ambient to reach its designed refrigerating temperature in the main compartment and freezing temperature in the freezer compartment. This is generally required to take place in a limited number of hours, and the thermal protector must not trip and prevent this from happening

In order to select a 4TM which has sufficient capacity to meet this requirement, the following information is needed:

- Maximum current the compressor draws during pull down
- Shell temperature under the 4TM and air temperature over the 4TM when maximum current draw occurs
- Maximum shell temperature during pull down
- Current and air temperature under the cover when maximum shell temperature occurs

This will be used to select a 4TM heater type and opening temperature which allow sufficient current carrying capacity to achieve

pull down, even with a minimum opening temperature 4TM.

• Running Overload

There are two running overload conditions which can cause motor overheating, and which can happen relatively easily: the condenser fan can be stopped or its air flow blocked, or the door can be left open causing continuous running of the compressor.

To prevent motor overheating, the current under each condition should be recorded along with the shell temperature and air temperature over the protector at the point where it is desired that a protector trip occurs. This point is generally related to the maximum motor temperature allowed by the compressor manufacturer; and the 4TM, even with the maximum opening temperature, should not permit operation of compressor beyond that point.

• Locked Rotor

The failure of the rotor to turn when the motor is energized will cause a large current inrush. The 4TM thermal protector should trip in a matter of seconds under this condition; cycle for an extended period of time (15 days required by UL); and limit the shell temperature to under 150°C (per UL) and motor winding temperature to the maximum value specified by the compressor manufacturer.

Locked rotor testing is generally conducted at nominal voltage, some percent less than nominal and some percent more than nominal. In each case, the inrush current needs to be recorded along with the observed rate of rise of the motor winding. If an electromechanical relay is used, the total line current is used. If a PTCR starter is used, the total

line current is recorded, the time at which the PTCR switches is noted, and the main winding only current is recorded. The "hot" current, or current recorded at the time of a desired protector trip, is also recorded. The required number of days of locked rotor cycling should also be stated.

• Power Outage

A special case of a locked rotor trip occurs when a power outage occurs for a short interval (seconds), and when a PTCR starter is used. If the compressor was running prior to the outage, the compressor would try to restart when power was restored; but the compressor motor would not be able to rotate due to high head pressure, and locked rotor current would be imposed on the motor and thermal protector, causing a protector trip. The PTCR starter and protector would then begin to cool. When the protector resets, it is desirable to have the PTCR starter cooled to allow sufficient time of high start winding current to accelerate the motor. Under this condition, it is useful to know how much off-time is desired from the protector to allow the PTCR to cool.

*Failure to properly apply the 4TM could result in actuation of the device when the compressor should be operating, or overheating of the motor during a fault condition.

Certification Agency Information

- UNDERWRITERS LABORATORIES, INC. - Recognized component, XEWR2, file E15962, issued 10-15-85
- CANADIAN STANDARDS ASSOC. - Certified file LR 11372-82C, issued May 14, 1986
- VDE - File No. 4464.4-4510-1010/A1C
Approval Document No. 2427 UG
250 VAC, 16 (16 max 16) AMPS
Overheat Protection, T175, 1.0K/min.
- SEMKO - T150, rated 250 VAC, 20 AMPS max.
- BEAB - (CO920) 250 VAC, 16 AMPS max.
- EN - 60730-2-4 250VAC, 16 AMPS max.

Technical and application assistance is available from our Marketing/Sales professionals located throughout the world.

4TM Thermal Protector Device Coding

TI Part Number **4TM 330 KFB YY - 53**

Basic Name for Thermal Motor Protector

Three Digit Heater Code
Coil - 100 thru 499
Flat - 700 thru 899

Three letter Code
Designates Disc, Operating Temperatures, and Tolerance
1st Letter - Opening Temperature
2nd Letter - Closing Temperature
3rd Letter - Tolerance

Denotes Contact Capacity
1st Letter Indicates Stationary Contact
2nd Letter Indicates Movable Arm Contact
Y - Low Capacity (Rated 20 AMP)
Z - High Capacity (rated 32 AMP)

External Terminations (Male Quick Connects)

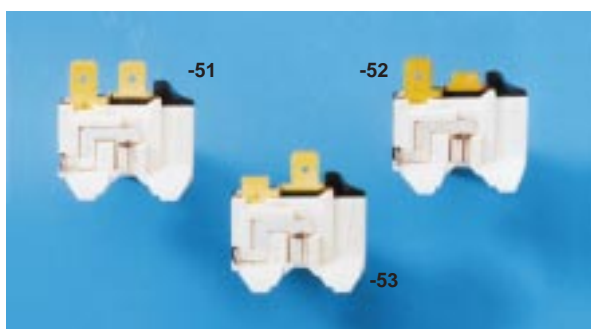

Contact Capacity (Cycle Life Guidelines)

The 4TM is designed to achieve a minimum of 10,000 cycles as defined by a Weibull analysis of test results. A failure is defined as open or permanently closed circuit, and a change in open temperature of greater than $\pm 5^{\circ}\text{C}$ or a change in reset temperature of $\pm 9^{\circ}\text{C}$ from the device's original value.

Test conditions are:

Contact	Operating Voltage	Max Current	Power Factor
ZZ	120	32 Amps	65%
YY	240	20 Amps	65%

This guideline is intended to direct users toward a proper selection of contact capacity for specific applications and judgement of acceptability of cycle rate on an application relative to their specific goals for cycle life reliability. It presumes that the heater capacity has not been exceeded, and only published combinations of open and reset temperatures are used.

The expected life of a given combination of 4TM and motor may well exceed the above guidelines by a considerable amount. Estimates of life of a given 4TM rating, in combination with a given compressor, may be obtained from a TI Sales/Marketing representative. It is incumbent upon the user to determine the reliability of the combination by actual locked rotor life test of the system.

Notes on Code

Heaters. Coiled heaters are preferred for PTCR-starter type applications because they provide longest off time; however, their ratio of first cycle trip time amps to ultimate trip amps is greater than flat heaters (approx. 4:1). Coiled heater series can cover a range of U.T.A. at 71°C from 0.7 amps to 5 amps.

Flat heaters are preferred for relay type applications due to their narrower ratio of trip time current to ultimate trip current (approx. 3:1). Flat heaters can cover a range of U.T.A. at 71°C from 0.9 amps to 8 amps.

Temperatures. Below is a list of standard operating temperatures, and each has $\pm 5^{\circ}\text{C}$ tolerance on open temp and $\pm 9^{\circ}\text{C}$ tolerance on reset temp. Consult your local TI Sales/Marketing representative for special requirements.

4TM Operating Temperatures

Temperature Code	Nominal Open	Nominal Close
JDB	100.0	52.0
KDB	105.0	52.0
KFB	105.0	61.0
LDB	110.0	52.0
LFB	110.0	61.0
MDB	115.0	52.0
MFB	115.0	61.0
MHB	115.0	69.0
NFB	120.0	61.0
NHB	120.0	69.0
PFB	125.0	61.0
PHB	125.0	69.0
REB	130.0	57.0
RFB	130.0	61.0
RHB	130.0	69.0
RLB	130.0	78.0
SFB	135.0	61.0
SHB	135.0	69.0
SLB	135.0	78.0
TFB	140.0	61.0
THB	140.0	69.0
TLB	140.0	78.0
UFB	145.0	61.0
UHB	145.0	69.0
ULB	145.0	78.0
VFB	150.0	61.0
VHB	150.0	69.0
VLB	150.0	78.0
VPB	150.0	87.0
WHB	155.0	69.0
WLB	155.0	78.0
WPB	155.0	87.0
XHB	160.0	69.0
XLB	160.0	78.0
XPB	160.0	87.0

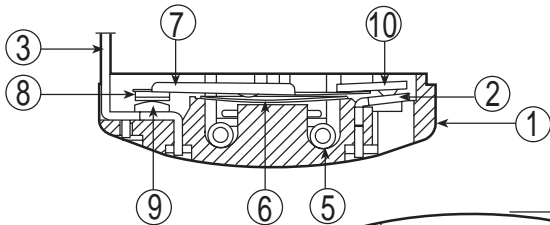
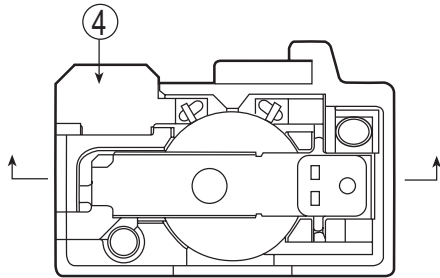
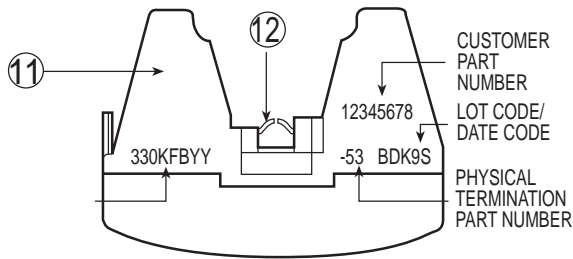

- ① Base, phenolic (UL 94V-0 rated)
- ② Movable arm support, plated steel
- ③ Stationary contact support, plated steel
- ④ Heater support, plated steel
- ⑤ Heater, resistance alloy
- ⑥ Disc, thermostatic alloy
- ⑦ Movable arm, spring temper copper alloy
- ⑧ Contact, movable, silver on copper
- ⑨ Contact stationary, silver on copper
- ⑩ Slug, plated steel
- ⑪ Cover, polyester (UL 94V-0 rated)
- ⑫ Pin connector, plated copper alloy (To engage 2.33/2.26 mm Dia. Pin)
- ⑬ Quick connect terminals, brass, conforms to UL 310, NEMA DC-2, DIN 46244

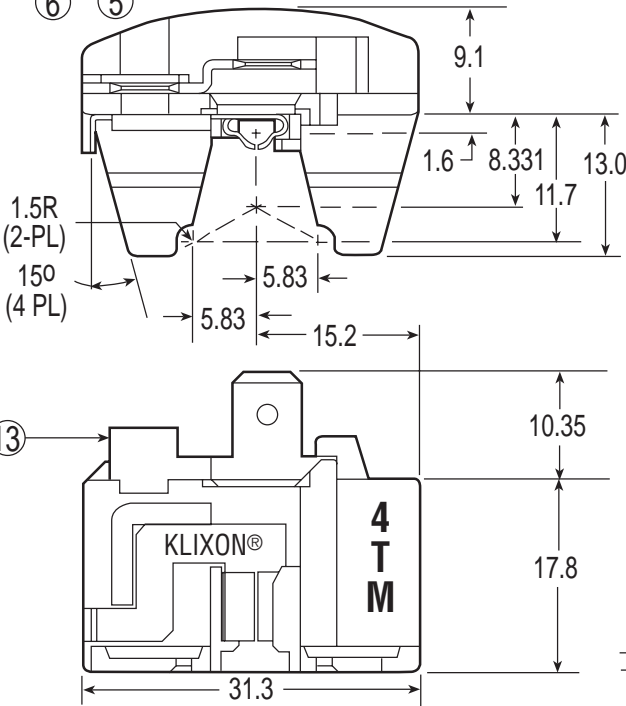

Note: Nominal dimensions for reference purpose only (Millimeters)

Conversion Chart	
Inches	mm
.006	0.15
.039	1.0
.059	1.5
.063	1.6
.110	2.8
.150	3.8
.230	5.83
.328	8.3
.390	9.9
.394	10.0
.460	11.7
.512	13.0
.598	15.2
.701	17.8
1.232	31.3

For more information on the TI 4TM Thermal Protector contact:
Texas Instruments Incorporated
Commercial Sensors & Controls,
MS 2-3
Attleboro, Massachusetts 02703
Telephone : 508 236-3800

or contact our sales/marketing professionals located throughout the world.

Important Notice: Texas Instruments (TI) reserves the right to make changes to or to discontinue any product or service identified in the publication without notice. TI advises its customers to obtain the latest version of the relevant information to verify, before placing orders, that the information being relied upon is current.

Texas Instruments assumes no responsibility for infringement of patents or rights of others based on Texas Instruments applications assistance or product specifications since TI does not possess full access concerning the use or application of customer products. Texas Instruments also assumes no responsibility for customer's' product designs.

